



BATALEON



**TRANSLATION
OF THE
ORIGINAL MANUAL
ISSUE I
11.2018**

OPERATION AND MAINTENANCE DOCUMENTATION RED LINE PLUS

INTRODUCTION

Dear User

Thank you for choosing the RED LINE PLUS heating boiler from BATALION. We hope that the device will meet your requirements and bring much satisfaction.

The RED LINE PLUS heating boiler was designed and manufactured according to the most important, current norms and standards, guaranteeing safety and dependable use. Using the device in accordance with the provided manual ensures effective and dependable operation.

BATALION

TABLE OF CONTENTS

1.	Initial activities (U).....	4
2.	Pictograms (U).....	4
3.	Applied symbols (U/I).....	4
4.	Definitions of terms in the manual (U/I).....	5
5.	General information (U).....	5
6.	Boiler equipment (U).....	5
7.	Use RED LINE PLUS (U/I).....	6
7.1	Basic elements of the boiler RED LINE PLUS (U/I).....	6
7.2	Basic dimensions of the boiler RED LINE PLUS (U/I).....	8
7.3	Technical specifications RED LINE PLUS (U/I).....	10
7.4	Fuel (U).....	11
8.	Requirements for the boiler room and boiler installation (U/I).....	11
8.1	Boiler installation (U/I).....	12
8.2	Connecting the boiler to the heating system (I).....	13
9.	Requirements for the expansion vessel (I).....	16
10.	Connecting the boiler to the power supply (I).....	16
11.	Connecting the boiler to the chimney (I).....	16
12.	Boiler start-up (U/I).....	17
13.	Tips when using the boiler (U).....	18
14.	Boiler maintenance and cleaning (U).....	18
15.	Illustration for utilising the boiler (U).....	19
16.	Possible faults and malfunctions (U).....	19
17.	Warranty conditions (U).....	21
18.	Certificate.....	22
	Conformity declaration.....	23
	Warranty Card for the steel boilers, central heating water boilers	24
	Warranty claim.....	25
	Warranty card.....	27
	Start-up report.....	29

USER (U) - actions concerning the person using the central heating boiler

INSTALLER (I) - actions concerning the person installing and servicing the central heating boiler

USER/INSTALLER (U/I) - actions concerning both of them

LIST OF TABLES

2.1	Pictograms.....	4
6.1	Boiler equipment.....	5
7.2.1	Boiler dimentions (mm) RED LINE PLUS.....	9
7.2.2	Dimentions of the supplementary burning chamber and charging inlet RED LINE PLUS.....	9
7.3	Boiler technical specifications Red Line Plus.....	10
8.1	Mass and building materials flammability.....	13
8.2.1	Symbols applied in the schematics.....	13
8.2.2	Symbols applied in the schematics.....	15
16.1	Possible faults and malfunctions.....	20

DESCRIPTION OF SCHEMATICS

7.1	Basic elements of the boiler RED LINE PLUS.....	7
7.2.1	Boiler dimentions RED LINE PLUS.....	8
7.2.2	Dimentions of the supplementary burning chamber and charging inlet RED LINE PLUS.....	9
8.1	Minimal requirements for the boiler room.....	12
8.2.1	Connecting the boiler to the heating system diagram.....	14
8.2.2	Connecting boilers to the heating system diagram.....	14
8.2.3	Connecting the boiler to the heating system.....	15
8.2.4	Connecting the boiler to the heating system with Laddomat and buffer.....	15

1. INITIAL ACTIVITIES

(USER)

Procedure to follow on delivery of the BATALION boiler:

- check if the boiler is complete (tab 6.1 page 5) and if it has not been damaged during delivery
- confront your order with the data plate, that is placed on the left or right on the boiler body
- read the user's manual carefully as it contains all the information required for safe operation of the boiler









If you happen to encounter any problems, please contact our service department or dedicated BATALION service centre.

The staff are trained and certified and have access to the original parts which ensure proper servicing and boiler installation.

2. PICTOGRAMS

(USER)

Table 2.1 Pictograms

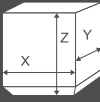
	5 year warranty		Movable grate
	6 mm certified boiler steel		Programmer
	Thermal efficiency up to 81%		Blower fan
	Water-cooled grate		Draught regulator
	Chimney draught regulation		Big loading chamber

3. APPLIED SYMBOLS

(USER/INSTALLER)



ATTENTION!

Very important piece of information that needs to be read



TIP!

Information that should be read to make operation easier.

4. DEFINITIONS OF TERMS IN THE MANUAL

(USER/INSTALLER)

Central heating boiler is a device intended to burn solid fuels in order to heat up the heat carrier (usually water) that circulates in the heating system.

Draught regulator is a device that regulates temperature in solid fuel boilers. as the temperature increases, the airflow fed into the furnace is limited thus slowing the burning process.

as the temperature drops, the airflow into the furnace increases thus encouraging the burning process.



Chimney draught regulator controls and lowers the excessive vacuum in the chimney system.

5. GENERAL INFORMATION

(USER)

The maintenance and operation documentation is a part of the product that comes with the delivered boiler. the documentation contains all the information concerning the construction characteristics, installation and operation of GTM boilers equipped with the RED LINE PLUS. A thorough study of the manual enables a proper and safe operation of the

ATTENTION!

 **Failure to comply with the provisions and guidelines included in this documentation as well as the nationally- recognised norms concerning such devices will make the producer's warranty and liability void.** 

Our boilers are shipped assembled. they are tightly attached to a pallet. some other forms of securing the boiler are used e.g. foil wrapping. during the shipping, the boiler should be tightly secured (e.g.with transport belts) so that it does not turn or move. the delivery should meet the requirements set in the general rules for transporting materials. the loading and unloading of the boilers should be carried out

using lifting devices (fork lift truck) of lifting capacity over 1000kg.

6. BOILER EQUIPMENT

(USER)

The delivery includes basic as well as additional elements depending on the type of order. on receiving the boiler you should carefully inspect the boiler to ensure that it has been delivered undamaged and complete. the additional and basic elements are listed below (tab 6.1).

Table 6.1 Boiler equipment

Basic equipment:	Unit	Number of items
Central heating boiler	pcs.	1
Ash drawer	pcs.	1
Thermometer	pcs.	1
Poker	pcs.	1
Brush	pcs.	1
Additional equipment:	Unit	Number of items
Draught regulator	pcs.	1
Documentation:	Unit	Number of items
Boiler maintenance and operation documentation	pcs.	1



ATTENTION!

Every user should familiarise themselves with the operation manual for the regulator, blower fan.



ATTENTION!

BATALION reserves the right to implement changes to the parameters, equipment and specification of the offered products without prior notice.



7. Use RED LINE PLUS

(USER/INSTALLER)

Steel water boilers are used for central heating and preparation of hot tap water for single-family houses and utility rooms, sales outlets, farms, public houses etc. they are equipped with a manual feeding grate. thanks to the newest construction solutions, the RED LINE PLUS boiler can reach the capacity of 81%.

The proper operation and highest performance of the boiler depends on the quality of installation, right flue and appropriate service and maintenance.

ATTENTION!

The boilers are designed to operate only with open system water installations with gravitational or forced circulation which are secured in accordance with PN-EN 13384-1:2004/ A1:2007 Heating and Calorifics



7.1 BASIC ELEMENTS OF THE BOILER RED LINE PLUS

(USER/INSTALLER)

The water chassis is a construction made from welded certified steel sheets of 5 mm thickness P265GH (for fumes interacting elements) and 4 mm (for other elements) S235JR+N.

Schematics description:

1. Charge door
2. Ash door
3. Cleaning hatch door
4. Air feeder
5. Feeder knob
6. Thermometer
7. Draught regulator stub
8. Movable grate lever
9. Grate door
10. Movable grate
11. Boiler body
12. Water- cooled grate
13. Return stub
14. Outlet stub
15. Ash container
16. Fumes throttle
17. Temperature sensor sleeve
18. Blower channel
19. Airflow channel
20. Adjustable screw
21. Airflow outlet
22. Boiler insulation

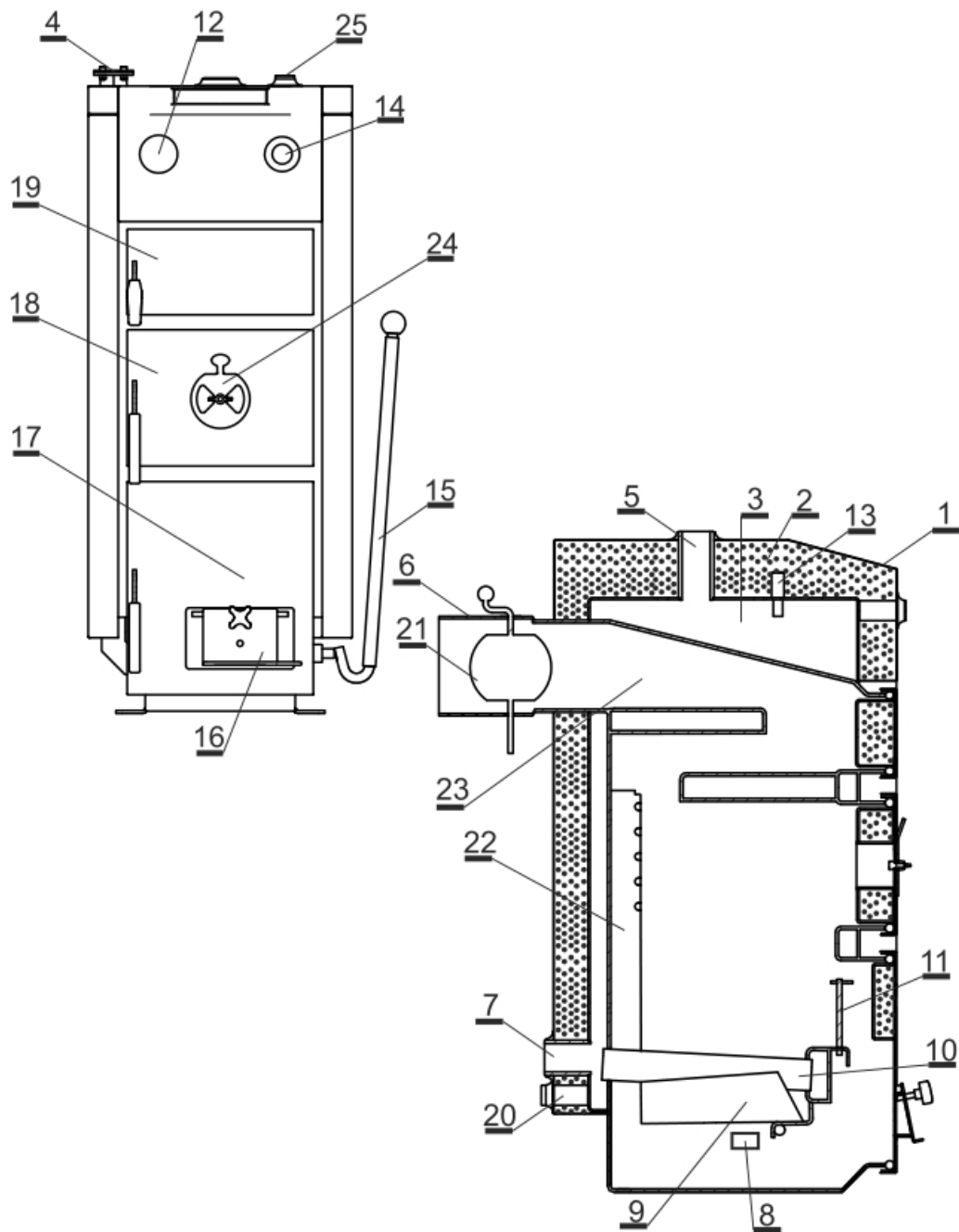

Description 7.1 Basic elements of the boiler RED LINE PLUS 10-15

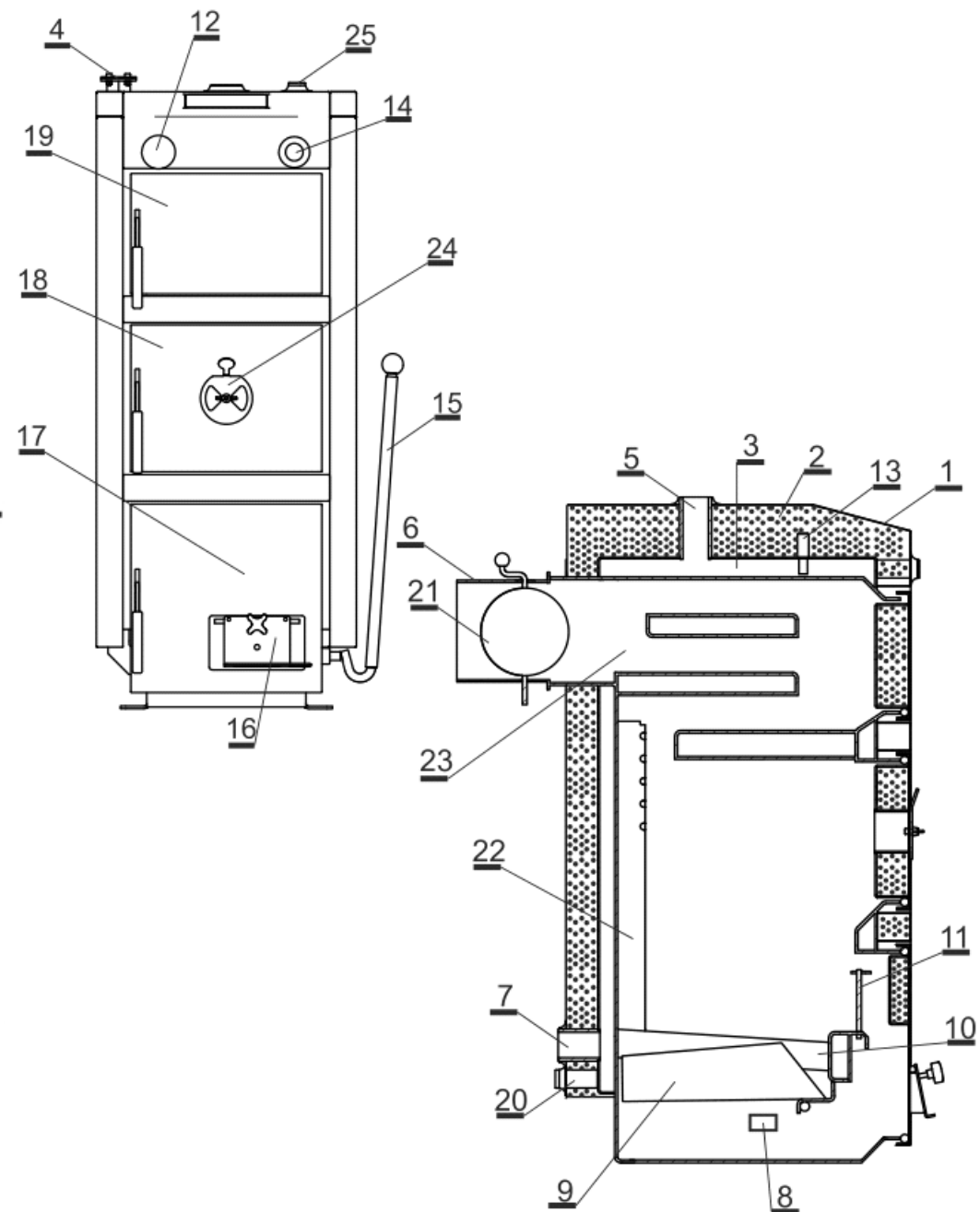

Description 7.1 Basic elements of the boiler RED LINE PLUS 20-30

7.2 BASIC DIMENTIONS OF THE BOILER RED LINE PLUS

(USER/INSTALLER)

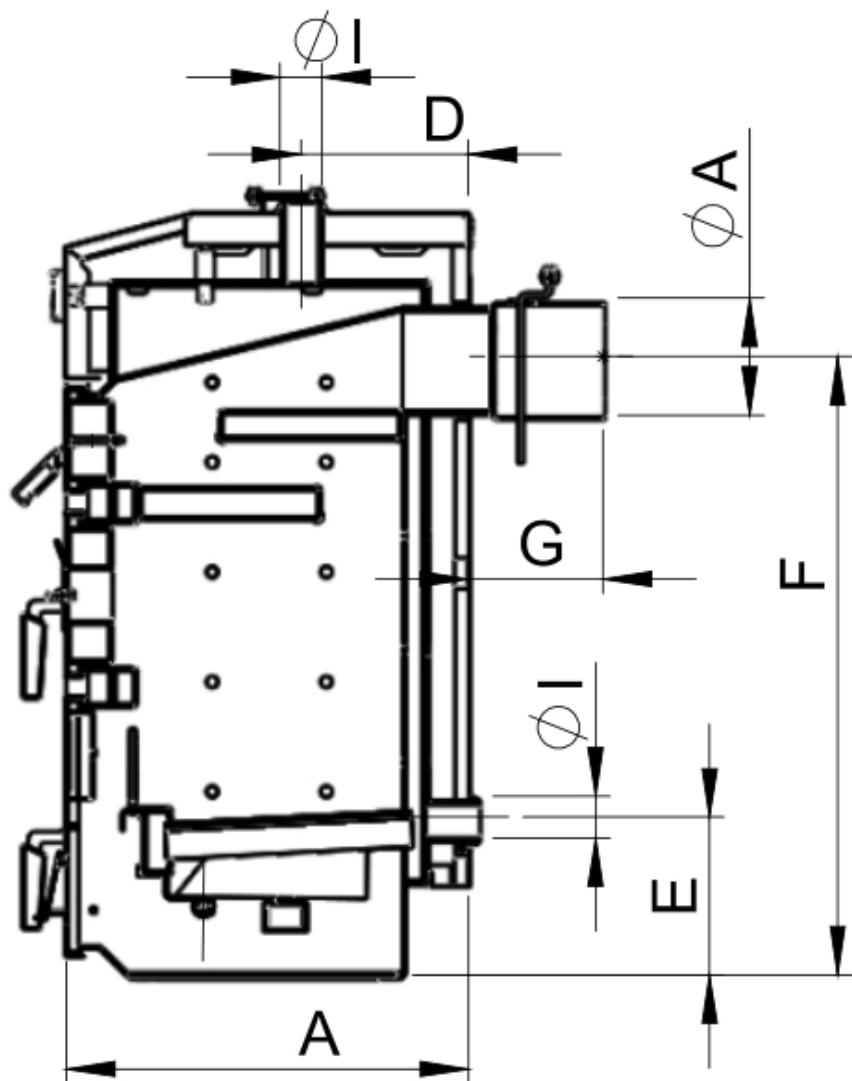

Description 7.2.1 Boiler dimentions RED LINE PLUS

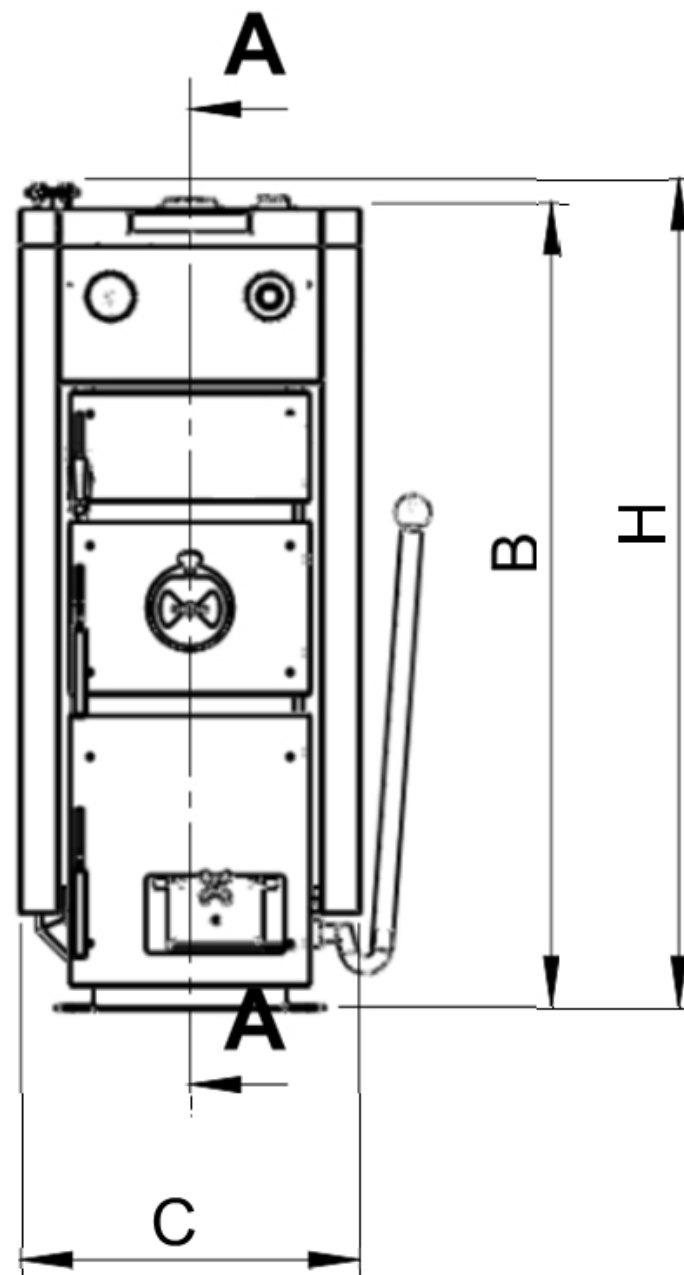

Description 7.2.1 Boiler dimentions RED LINE PLUS

Table 7.2.1 Boiler dimensions (mm) RED LINE PLUS

Type	RED LINE PLUS - 10	RED LINE PLUS - 15	RED LINE PLUS - 20	RED LINE PLUS - 25	RED LINE PLUS - 30
A	550	600	610	640	690
B	1050	1050	1165	1165	1165
C	440	490	490	540	590
D	230	280	230	260	260
E	215	215	210	210	210
F	844	844	940	940	940
G	184	184	190	190	190
H	1070	1070	1190	1190	1190
ØI	1 1/2	1 1/2	1 1/2	1 1/2	1 1/2
ØI	160	160	180	180	180

ATTENTION!



The manufacturer reserves the right to implement any construction changes during modernisation of the product.

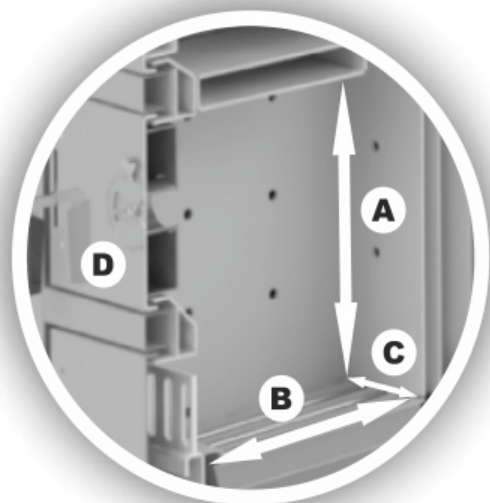

Table 7.2.2 Dimensions (mm) of the supplementary burning chamber and charging inlet RED LINE PLUS

Type	RED LINE PLUS 10	RED LINE PLUS 15	RED LINE PLUS 20	RED LINE PLUS 25	RED LINE PLUS 30
A	400	400	500	500	500
B	360	410	420	450	500
C	250	300	300	350	400
D	200x250	200x300	250x300	250x300	250x400

Description 7.2.2 Dimensions of the supplementary burning chamber and charging inlet RED LINE PLUS

7.3 TECHNICAL SPECIFICATIONS

RED LINE PLUS

(USER/INSTALLER)

Table 7.3 Boiler technical specifications RED LINE PLUS

Parameters	Unit	Type of boiler					
		RED LINE PLUS - 10	RED LINE PLUS - 15	RED LINE PLUS - 20	RED LINE PLUS - 25	RED LINE PLUS - 30	
Nominal thermal output (coal)	[kW]	10	15	20	25	30	
Heating surface	[m ²]	1,1	1,4	1,8	2,1	2,5	
Boiler water capacity	[L]	39	50	48	65	74	
Maximum working pressure	[Bar]	1,5	1,5	1,5	1,5	1,5	
Maximum working temperature	[°C]	95	95	95	95	95	
Test pressure	[Bar]	4	4	4	4	4	
Boiler class	-	3	3	3	3	3	
Boiler efficiency	[%]	≤81	≤81	≤81	≤81	≤81	
Burn time at nominal power	[h]	-	-	-	-	-	
Fuel	-	coal, wood					
Required chimney flue	[Pa]	20	23	23	23	25	
Flow resistance δt	[mBar]	[10K]	0,14	0,30	0,42	1,05	1,7
		[20K]	0,07	0,15	0,21	0,55	0,85
Boiler weight	[kg]	160	194	224	250	290	

7.4 FUEL

(USER)

The fuel intended to be burnt in RED LINE PLUS type is deciduous wood under 20% humidity and coal of OI sort. the recommended types of wood are beech, hornbeam, oak, willow, alder or ash.

It is not advised to use coniferous logs as they produce a lot of soot in the boiler, requiring it to be cleaned often.

ATTENTION!



If the humidity of wood you use is over 20%, it is recommended to install an insert made from acidproof steel.



8. REQUIREMENTS FOR THE BOILER ROOM AND BOILER INSTALLATION

(USER/INSTALLER)

In Poland, all the solid fuels boilers should be made in accordance with PN- 87/B-02411 Norm „Solid fuels boilers”. they have been divided into two categories.

1) For small boilers under 25 kW, the following requirements should be met:

- the boiler should be placed in the central position to the heated rooms and in a separate room.
- the floor surface should be inflammable. if the floor is flammable, it should be covered with steel metal sheet of 0,7 mm thickness and exceed the boiler contour by at least 50 cm. the boiler should be placed on inflammable base of 0,5 cm above the floor and secured by steel angles.
- the boiler room can be lit naturally as well as artificially.
- the location of the boiler in the room should enable free access to the boiler during cleaning and maintenance works. The distance between the back of the boiler and a wall should be at least 70 cm, the side of the boiler and a wall should be at least 100 cm and the front of the boiler and a wall opposite should be at least 200 cm;
- the height in a new building should be at least 220 cm. in old buildings the the boiler room should be at least 190 cm high as long as the

ventilation inside is sufficient (supply- exhaust ventilation)

- supply ventilation should be provided by an open slot of 200 cm² in diameter and placed up to 100 cm over the floor surface.
- the exhaust ventilation should be provided by an exhaust duct of 14 x 14 diameter and made from noncombustible material. its outlet should be installed under the ceiling of the boiler room. the exhaust duct should lead out over the roof and placed in the close vicinity of the chimney. no shut down equipment can be installed on the duct.

2) Boiler rooms of heating power greater than 25kW should meet extra requirements, such as:

- the distance to the far-most chimney, at gravitational draught, cannot exceed 50 cm of the chimney height.
- the fuel and slag store should be located by the boiler room. The storing height up to 220 cm with a 50 cm free space above it.
- the equipment for vertical and horizontal delivery of the fuel and slag should be considered.
- the fuel store should be equipped with natural ventilation that allows for full airing once an hour in the fuel store and three airing circles an hour in the slag store.
- the entrance door to the boiler room should be fire- resistant (0,5 class of fire resistance), the minimum width 80cm and should open outside. the door should have a handle- free system when opened from the inside and have a door handle when coming inside
- the requirements for the ventilation are the same as those for the boiler rooms of lower power; additionally, in the boiler rooms of power greater than 400 kW, the supply exhaust ventilation should be accompanied by mechanical ventilation that can be periodically activated when feeding the fuel and removing slag. it must also be able to provide 10 airing circles an hour
- natural lightning which can light the front of the boiler should be considered in the room. the total surface of the windows should equal at least 1/15 of the floor surface; half of the windows in the room should open; the electrical lightning and electrical socket of max. 24 V should also be located in the room
- inspection chamber that will allow cooling water should be located in the floor; its capacity should equal the water capacity of the biggest boiler but not exceed 2m³

- in the boiler room all the heating pipes should be insulated
The placing of the boiler together with the minimum distance requirements is presented in the boiler room schematics (8.1)

TIP!
The rules included in the law serve only as guidelines which must be verified as the law is amended.

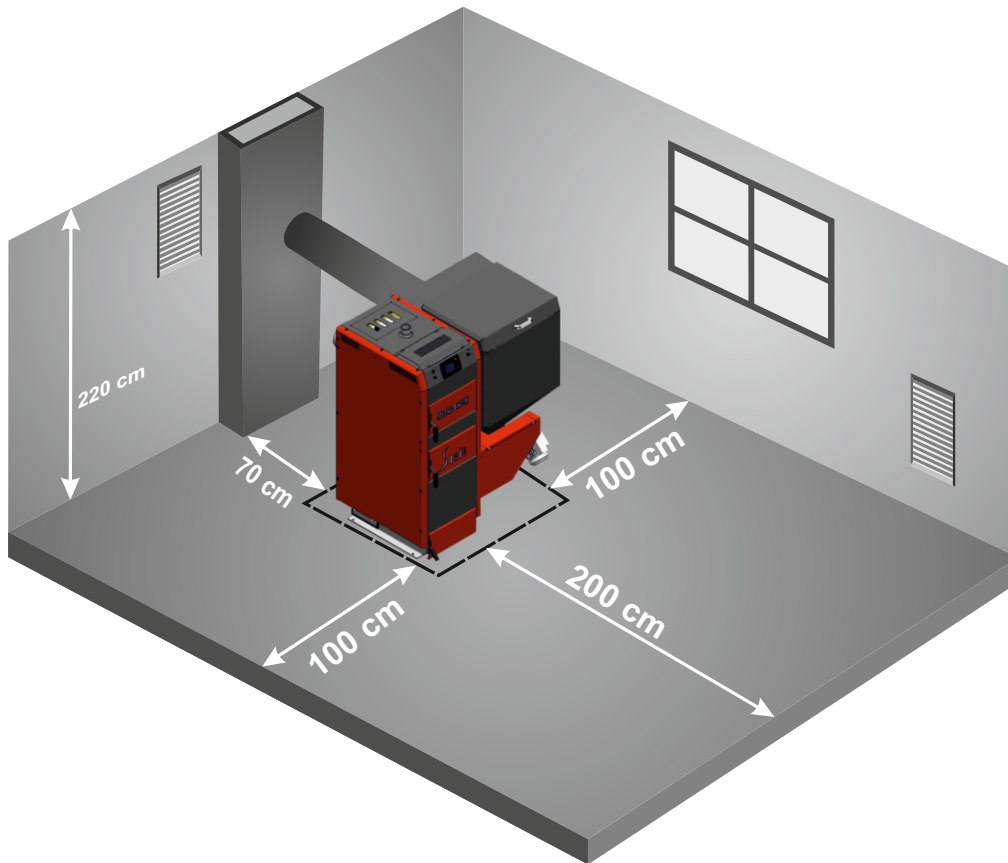

Description 8.1 Minimal requirements for the boiler room

- ATTENTION!**
The mechanical exhaust ventilation should not be used in the boiler room
- ATTENTION!**
Correct fresh air infeed to the boiler room will ensure efficient fuel burn.
- ATTENTION!**
Ensure that the carbon dioxide level in the room is not too high.
- ATTENTION!**
For more information on boiler room construction, refer to the 12.03.2009 Minister of Infrastructure Law.

8.1 BOILER INSTALLATION

(USER/INSTALLER)

The important element of installation is correct setting and levelling of the RED LINE PLUS boilers. the boilers do not require special base and need to be leveled with adjustable feet. the boiler must be set in the vertical position.

The boiler must be placed on a flameproof pad that exceeds the boiler outline by 2 cm. if the boiler is located in the basement, it is recommended that it is placed on a base of at least 5 cm thick. the bearing of the floor and the fire hazard conditions are the key elements of choosing the right location for the boiler i.e:

- 20 cm from any flammable materials
- 40 cm from any flammable materials of C3 flammability
- 40 cm from any flammable materials of unknown flammability

Table 8.1 Mass and building materials flammability

Flammability of construction products:	Construction products
A- noncombustible	Sandstone, concrete, bricks, fire-resistant plaster, (concrete/ cement) mortar, tiles, granite
B- difficult to ignite	Wood- cement boards/beams, fibreglass, mineral insulation
C1- difficult to ignite	Beech wood, oak wood, plywood
C2- normal combustibility	Pine, larch and spruce wood, cork, plank boards, rubber floorings
C3-Easily ignited	Asphalt plywood, celluloid compound, polyurethane, polystyrene, polyethylene, plastics, PVC

 **ATTENTION!** If the boiler is not levelled properly it can be damaged. 



 **ATTENTION!** The boiler must not be placed in a damp and wet room as the enhanced corrosion process will shortly damage the boiler. 

8.2 CONNECTING THE BOILER TO THE HEATING SYSTEM

(INSTALLER)

The connecting of the boiler to the central heating system should be contracted to a producer- certified company. this procedure should be confirmed in the warranty card which is attached to this manual. the boiler must be connected according to the manufacturer's guidelines and this manual.

 **ATTENTION!** It is required that the boiler is connected to the heating installation by a four- way valve. 

 **ATTENTION!** The temperature of the return water from the central heating boiler should not be lower than 45°C. 

 **ATTENTION!** Ensure that the thermometre capillary is tightened and sealed. 

Table 8.2.1 Symbols applied in the schematics

Designation	Key
RO	deaeration pipe
RW	expansion pipe
RS	signal pipe
RP	spill pipe
RB	safety pipe
T1	temperature
P1	pressure

The schematics of the connecting the boiler to the heating installation meet the PN- 91/B-02420 requirements.

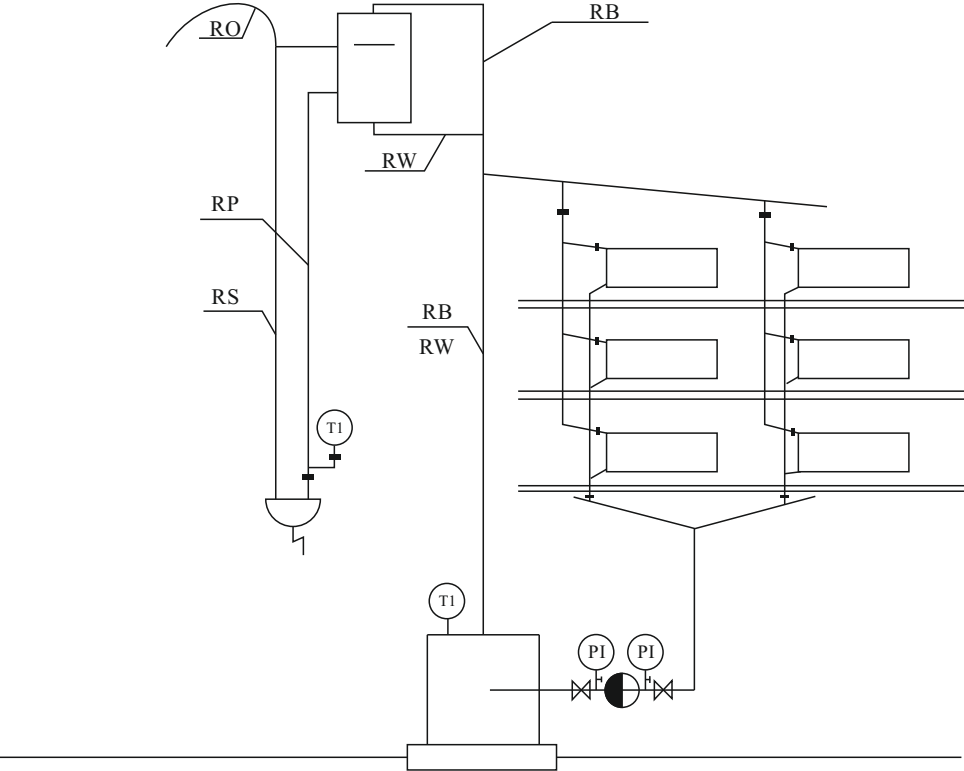

Description 8.2.1 Connecting the boiler to the heating system diagram

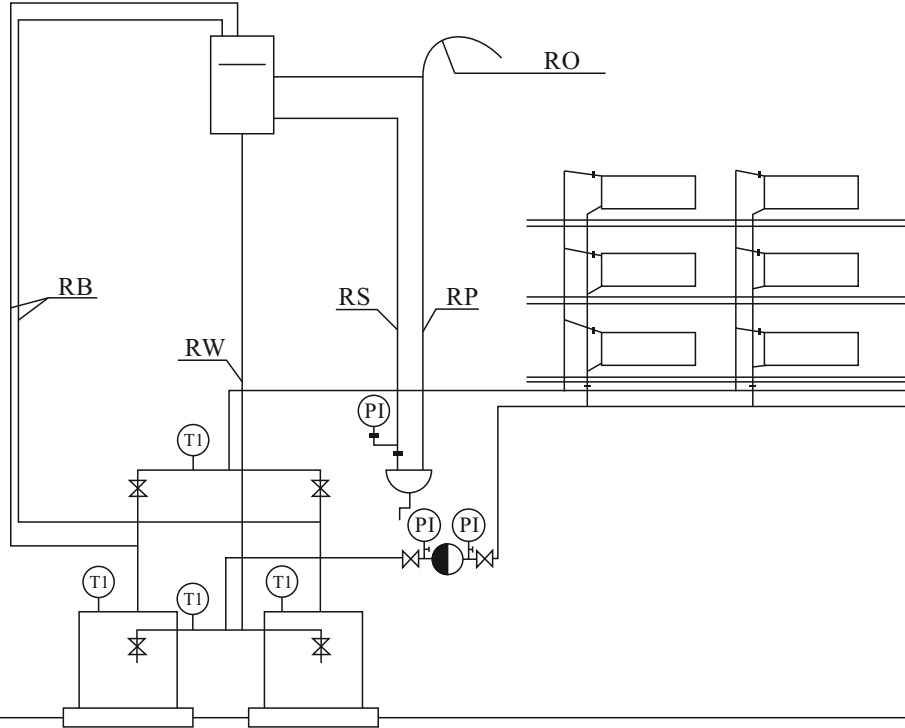

Description 8.2.2 Connecting boilers to the heating system diagram

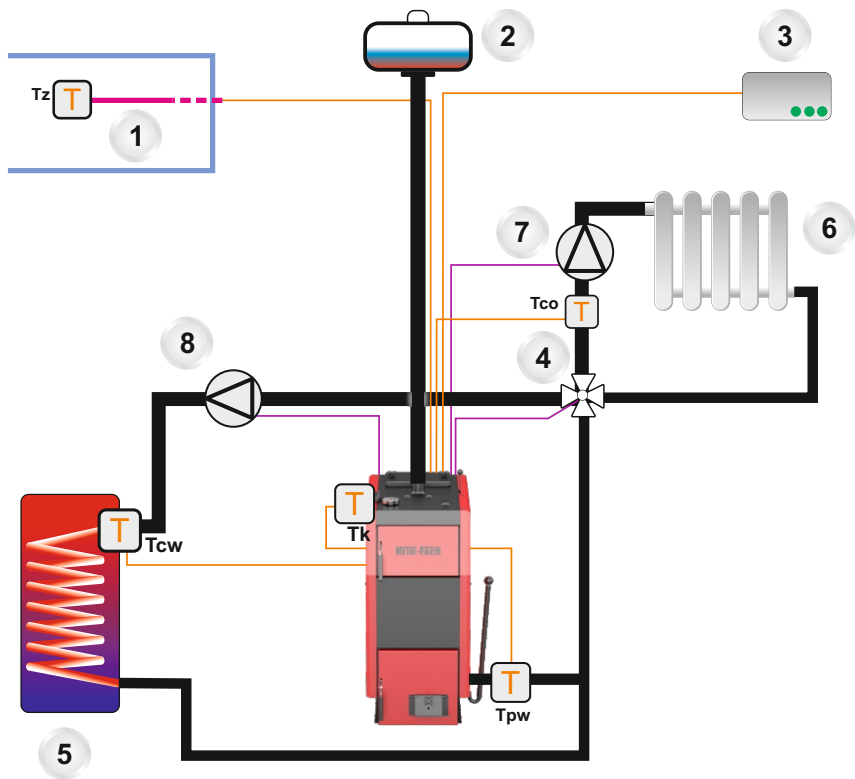

Description 8.2.3 Connecting the boiler to the heating system

Table 8.2.2 Symbols applied in the schematics

Designation	Key
T	temperature sensor
Tk	boiler temperature sensor
Tz	outside temperature sensor
Tcw	hot tap water temperature sensor
Tco	central heating temperature sensor
Tpw	return water temperature
Tpod	feeder temperature sensor

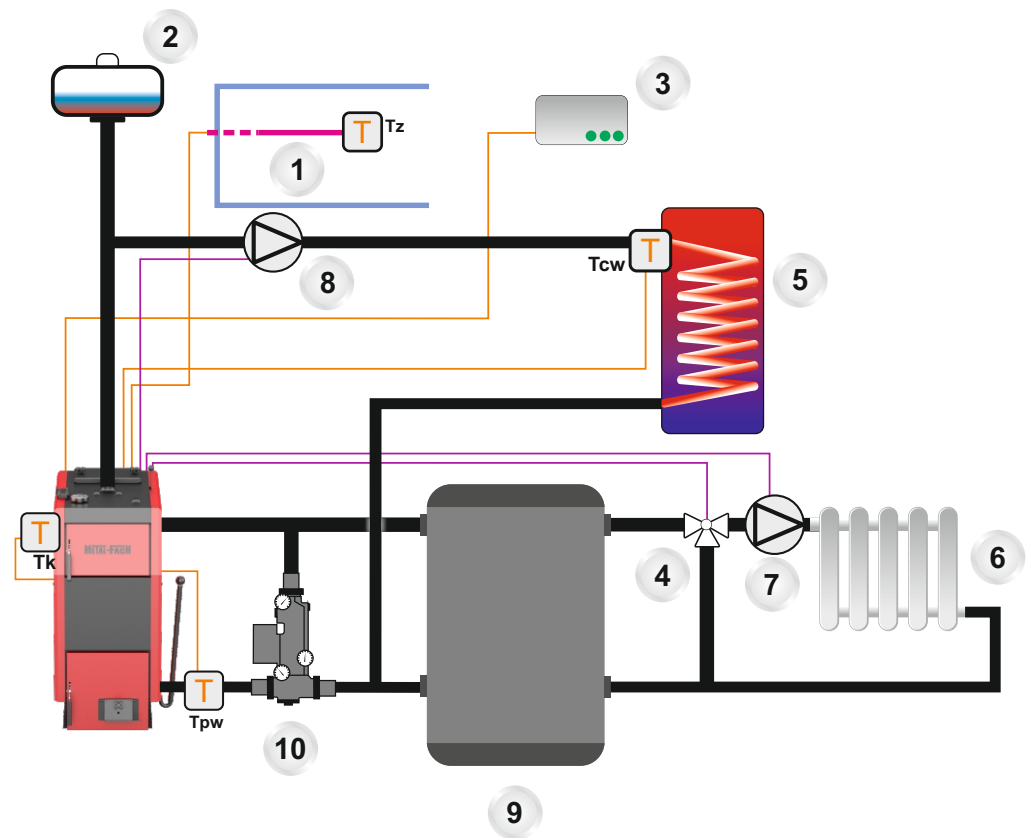

Description 8.2.4 Connecting the boiler to the heating system with Laddomat and buffer

Figure description:
 1. Outside the building
 2. Expansion vessel
 3. Room regulator
 4. Mixer
 5. Heater

6. Heating circle
 7. Central heating pump (CO)
 8. Hot tap water pump (CWU)
 9. Block
 10. Laddomat

9. REQUIREMENTS FOR THE EXPANSION VESSEL

(INSTALLER)

Every open water heating installation should be equipped with an expansion vessel, which receives excess water volume and deaerates the installation. The vessel should be installed in the top-most point of the installation, and if possible, vertically above the boiler (boilers). The capacity of the vessel should be calculated using the unit capacity for every kW of power at 1-2 dm³. The expansion vessel is equipped in stubs to connect a riser safety tube, safety downpipe, and a spill pipe and - connected to it - deaeration.

The diameter of the deaeration and spill pipe should be at least

$$d = 15 + 1,39\sqrt{Q} \text{ [mm]}$$

Q - Boiler efficiency [kW]

The most important requirements on the operation of the device are the following:

- The expansion vessel should be about 3.5% of the total water volume in the water heating installation and boiler.
- Each boiler must have a safety tube and spill-pipe.
- Installation should be equipped with a signal pipe and expansion pipe, and a stub for deaerating the expansion vessel.

In the case of several boilers, each should have its own safety pipe in accordance with the guidelines in PN-91/B-02413. Safety and spill pipes should not have any closing valves, and the pipes and vessel should be protected from freezing.

10. CONNECTING THE BOILER TO THE POWER SUPPLY

(INSTALLER)

The boiler is designed for 230V/50 Hz voltage. such connection should be carried out by a certified specialist. the 230V/10A connection socket with grounding should be easily accessible. the power supply to the boiler and room lighting should have own circuit. the finishing and heating test should be noted in the Warranty Card. the Warranty Card should then be sent over to the manufacturer in order for the user to be registered in the company system.

ATTENTION!

The start-up of the boiler should be carried out by the manufacturer- certified and trained company with a valid BATALION Distributor or Service Technician Certificate.



11. CONNECTING THE BOILER TO THE CHIMNEY

(INSTALLER)

Smoke flue

The flue pipes extract the fumes outside and intake air used for burning fuel.

The necessary draught depends on:

- the temperature difference between the hot fumes and cold air
- proper chimney height
- the chimney diameter should be no less than 20 x 20 cm
- chimney properties (smooth surfaces inside and outside) grout tightness

The effective height of the chimney is the difference between the highest grate and the flue outlet. The effective height of the individual chimneys must be at least 4 m and of collective chimneys for solid and liquid fuels should be at least 5 m. the difference between the two grates can't be greater than 6,5 m.

In case of sloping roofs, the chimneys should end at the ridge, in the area of free wind. It prevents any draught brakes. Pay attention to the location of the building in relation to the buildings around.

Choosing chimney

In most cases, choosing the right chimney is done by using an approximation method or according to manufacturer's recommendations. In special cases (bad pressure conditions, large volume of fumes) the chimneys are chosen according to the PN-EN 13384-1+A2:2008 Norm.

Chimneys for solid fuels boilers

It must be noted that the solid fuel grates of nominal thermal power of >20 kW and without vent require separate chimney. For the solid fuel grates, single-layer brick chimneys can be used. Today, three-layer chimneys of smooth surface and good thermal insulation are commonly used.

Flue

The boiler is connected to the chimney with a flue and smoke flue. The smoke flue consists of pipes and fittings which are set in rooms. The smoke flues meet the requirements set in the chimney fire hazard regulations and are often made from the same material as the main chimney. The smoke flues should be made from non-flammable materials. The smoke flues or their housings should meet the requirements set in the small chimneys fire test Polish Norm. It is allowed to build the housing from solid bricks of 12 cm thickness. The bricks should be set on the cement- plaster mortar with outer plaster or binder. The connections should be kept as short as possible and set in the upright direction to the chimney in order to avoid heat losses and additional resistance. They cannot be set to other rooms. The fumes pipes should not be set in rooms where furnaces cannot be installed, moreover, they cannot be installed in walls and ceilings. Due to low fumes temperature, in order to protect the chimney from dampness and draught limit, use the acid- resistant or ceramic chimney liners with condensate discharge to the waste drain. The distance between the chimney and the closest tree top line should be at least 6m.

12. BOILER START-UP

(USER/INSTALLER)

Before starting fire in the boiler, make sure that the central heating installation has been installed properly and filled with water- until it flows

over through the overflow pipe from the expansion vessel. For the best results, the installation should ideally be filled with softened water/ chemically treated water, distilled water or rain water.

Also, ensure that the grate has been cleaned from any unburnt fuel, ash and slag from the previous burning and make sure that ash has been removed from the tray.

Proper kindling (from top down)- once the grate base is ready, fill it up with fuel, (full load), place ignition layer (paper, wood chips) and then ignite. The boiler start-up must be done with the return air throttle open in the charge door.

It is not advisable to kindle the fuel from bottom up in the upper burn boilers.

Before igniting the layer, make sure that the chimney has proper flue. Insufficient flue occurs during the boiler start-up or after the boiler has been idle for a long time or the boiler and the chimney have been cooled off.

In this case, before igniting the layer, you should heat up the chimney in the following way:

- put few wood chips into the flue and ignite them
- keep the fire going for as long as possible until the chimney draught increases (the flame is sucked into the chimney)
- after the wood has burnt out, remove any remains and place them in the ash tray

Once the required water temperature is reached in the boiler, adjust the combustion intensity. The combustion intensity is adjusted by proper regulation screw setting. During normal boiler operation you should periodically monitor and top up the fuel in the way presented above. In case of coal with sintering properties the fuel might hang over the grate. Its symptom is that although the chamber is filled up with coal, the boiler efficiency drops. If situation occurs, open the charging door and knock down any fuel leftovers with a metal rod.

When opening the charge door, be extra careful as sudden opening of the door may cause gas ignition (degassing products). When opening the door, stand next to the boiler, open slightly and wait a moment until the fumes are extracted from the fuel bin and then slowly open the door ajar. Also in this situation you should not stand in front of the door. Remember about these tips when opening any doors of the boiler.

After starting a cold boiler, or at first start-up, the boiler can "sweat". It

may seem like it is leaking. In such case, you must perform intense combustion (70-80°C) in order to dry and warm the boiler and chimney vent through, even for 2-3 days.

To ensure longer boiler operation, it is advised to keep the fumes temperature 180°C above the outside temperature and the water temperature in the boiler should not be lower than 60°C.

In such situation, keeping an appropriately low temperature in the radiators in the autumn-spring season can be done, amongst others, by:

- Properly selecting the boiler to the heated rooms.
- Using, between the infeed and return of water, three- or four-way mixing valves, operated manually or automatically.

Improper heat insulation of the expansion vessel can also lead to boiler explosion and all following consequences.

If the water in the expansion vessel freezes, it severs the connection between the heating installation and boiler and the atmosphere, and when temperature of boiler water rises uncontrolled, it may lead to boiler explosion.

ATTENTION!

If, by any reason, there is no water in the boiler-installation system, it should not be refilled with cold water. Cool the boiler down as quickly as possible to 30°C (if necessary, remove burning fuel), and only then refill the water and start up the boiler anew.



ATTENTION!

The cold water infeed to the boiler walls, while they are hot, bears the risk of boiler explosion, and, consequently, destruction of the heating devices. In extreme cases, it can lead to damage to the building and people.



ATTENTION!

Do not stand directly in front of the boiler when opening the boiler door- it may cause burning.



13. TIPS WHEN USING THE BOILER

(USER)

- the boiler can be operated by two adults who have familiarized themselves with the manual
- the presence of unsupervised children in the boiler room, or allowing them to operate the boiler is forbidden.
- ensure that the boiler is switched off during any works with flammable materials that emit flammable gases or fumes e.g. glueing, painting etc.)
- turn off the boiler before clearing out the exhaust carbon from the retort, gutter etc. („OFF” position)
- turn off the boiler before stoking the boiler („OFF” position)
- do not use flammable liquids for igniting the boiler, the boiler ignites automatically (ignition)
- turn off the boiler before cleaning
- do not overheat the boiler
- do not place any flammable material in the close vicinity of the boiler
- during ash removal, any flammable materials should be kept at a distance of 150 cm from the boiler
- the ash should be placed in heat resistant containers with a lid
- if the boiler operates at the temperature lower than 60°C, the steel exchanger may „sweat” and cause corrosion that shortens the boiler life span. That is why the minimum operation temperature of the boiler should be 60°C
- after the heating season is over, the boiler and the smoke duct must be thoroughly cleaned
- the boiler room should be kept tidy and dry

ATTENTION!

The boiler is not meant to be operated by persons of lowered mental or physical independence or by persons with no experience or limited knowledge about the product if they are not supervised or instructed by the person responsible for their safety.



ATTENTION!

Any tampering with the boiler electronic system or boiler construction is forbidden.



14. BOILER MAINTENENCE AND CLEANING

(USER)



ATTENTION!
Clean the boiler only when it is disconnected from the power supply.



In order to save fuel, the burner chamber as well as the convection channels must be kept clean. The walls and the grates in the burner chamber should be cleaned through the charger and burner doors. The boiler exchanger should also be cleaned regularly. The convection channels and the flue should be cleaned through cleaning hatch on the boiler flue or at the bottom in the side wall. It should be carried out with expendable metal brushes. The boiler should be cleaned during the idle period, preferrably every 100 hours.

A thorough cleaning of the boiler should be done monthly. If the fuel is of low quality, cleaning should be done more often.

15. ISTRUCTION FOR UTILISING THE BOILER

(USER)

Before scrapping the boiler, all the electronic elements should be removed. They should be disposed of according to the 2002/96/WE Electric and Electronic Equipment. In order to dispose of the electronic elements you should contact the manufacturer. The steel elements the boiler is made from should be scrapped in the dedicated locations (scrap yards).



ATTENTION!
The boiler and its elements should not be disposed of together with other waste.



16. POSSIBLE FAULTS AND MALFUNCTIONS

(USER)

Before calling the helpline read the FAQ section of the manual.



ATTENTION!
Please remember that in the case of unnecessary customer support, the customer covers the costs of calling and work of the support unit.



Table 16.1 Possible faults and malfunctions

Question	Answer	Explanation
Smoke from charge door or ash door.	<ul style="list-style-type: none"> -no draught -improper boiler-chimney connection - fuel remains in the hinge or sealant. - another boiler connected to the same chimney vent - insufficient chimney diameter. 	<ul style="list-style-type: none"> - tighten wall in the connection of the flue and chimney vent - check the patency of the chimney, and its parameters - check the sealant on the door - seal the outlet of the boiler to the chimney vent, preventing the suction of cool air - extend the diameter of the chimney vent.
There is water coming from the boiler during the first start-up (leakage).	Condensation (sweating of the boiler).	Heat the boiler above 80°C and keep this temperature for at least 6 hours. If necessary, repeat.
Temperature on the boiler is too low.	<ul style="list-style-type: none"> - wrong selection of power (boiler size) - calorific value of fuel too low - improper boiler regulation. 	<ul style="list-style-type: none"> - see the chapter on boiler use and maintenance - wrong selection of power.
Sudden rise in temperature and pressure.	<ul style="list-style-type: none"> - the ash chamber is not sealed - the chimney diameter is too big. 	<ul style="list-style-type: none"> - seal up the doors or cleaning doors (if present) - decrease the chimney vent diameter.
Water leakage in the convection channels.	<ul style="list-style-type: none"> - incorrect fuel - too low combustion temperature - no air through the air throttle - closed flue gas throttle. 	<ul style="list-style-type: none"> - use fuel of proper energy value and humidity - open the air throttle - open the flue gas throttle.

17. WARRANTY CONDITIONS

(USER)

1. Hot water boiler warranty, confirmed with the seal of the manufacturer of point of sale and the signature of the seller, is granted for the period

- 5 years from date of purchase, but not longer than 72 months from production, for the tightness of the exchanger and use of the boiler safety devices before returning cold water (four-way valve, loddomat, etc.);

- 2 years for correct function of the boiler

- 1 year for moving, cast iron, and mechanical elements, and screw

Warranty does not include wear materials (sealing rope, gaskets). The warranty for RED LINE PLUS boiler is granted under the condition of issuing a complete payment for the boiler, and sending to the manufacturer a properly filled Warranty Card.

2. In case of damage of material faults during the warranty period, the manufacturer ensures free repair.

3. The manufacturer is obligated to perform the repairs within 14 days from the date of submitting the boiler to repair by the buyer.

4. The warranty is extended by the period from the date of submission of the fault to the day of informing the buyer about the completion of the repairs. This period is confirmed in the warranty card.

5. Repair of the boiler in the warranty period by persons not authorized by the manufacturer, releases the manufacturer of any warranty obligations.

6. Any damages due to incorrect use, improper storage, incompetent maintenance, non-conforming to the conditions outlined in this operation and maintenance manual, and due to reasons outside the manufacturer's power, make the warranty void, if these damages led to changes in the boiler.

7. The warranty does not include elements, which were damaged due to user carelessness and non-conformity with the manual, as well as boiler equipment: Thermometer, valves, cocks, etc., purchased by the manufacturer as boiler equipment.

8. The purchaser may seek warranty claims only when the manufacturer does not perform his warranty obligations.

9. The boiler can be replaced when the manufacturer states, on the basis of a certified expert opinion, that he cannot repair that boiler.

10. The warranty card is the only basis for free warranty repairs for the

purchaser.

11. Warranty card without dates, seals, signatures, or with corrections and deletions made by unauthorized persons, is invalid.

12. No duplicates are issued if the warranty card is misplaced.

13. The pin guarding the screw throttle is not included in the warranty. It can get damaged when using incorrect fuel. The replacement of the pin by a support serviceman is charged.

14. The sealing rope in the combustion chamber door and cleaning openings, is not included in the warranty, nor is it included for replacement. It is an operating material.

15. Any electrical devices provided with the boiler are under separate warranty by the manufacturer of these devices.

16. The Warrant can charge the Purchaser in case of unnecessary support.

17. The warranty is in force on the territory of the EU.

18. The warranty for consumer goods, does not exclude, limit, or withhold the rights of the purchaser stemming from non-conformity with the contract.

19. The condition of recognizing the warranty is the submission of the proof of purchase and properly filled warranty card.

20. First startup of the boiler, as well as any other repairs and actions outside the scope of user actions described in this manual, can be performed only by a manufacturer certified service. First startup cost is covered by the user.

BATALION Patryk Kucharewicz is not liable for an inappropriate selection of boiler in relation to the heating surface. If the warranty call is unnecessary, the cost of travel of manufacturer service unit is covered by the warrantee.

THE WARRANTY IS VOID WHEN:

1. The boiler is connected to a closed installation.

2. There are damages from overheating the boiler.

3. There are damages due to non-conformity to the guidelines in this manual.

CONFORMITY DECLARATION

1. Manufacturer

BATALION Patryk Kucharewicz
Ul. Sikorskiego 66
16-100 Sokółka
NIP 545-181-18-03

2. Product name and intended use.

Solid fuel steel central heating boiler with automatic feeder.

Type RED LINE PLUS..... Manufacturer's number..... Year of production.....

I. Dokumenty odniesienia:

1. Regulation of the Polish Minister of Economy of 21.12.2005 on the essential requirements of pressure devices and sets of pressure devices (Polish Journal of Laws no. 263 item 2200).

Pressure Directive 97/23/EWG.

2. Regulation of the Polish Minister of Economy of 21.10.2008 on the essential requirements of mechanical devices (Polish Journal of Laws no. 199 item 1228) with change published in Polish Journal of Laws 2011 no. 124 item 701. Directive 2006/42/WE Machinery.

II. Technical documentation:

1. Norm PN-EN 303-5:2012: Heating boilers for solid fuels, hand and automatically stocked of nominal power of 500 kW.

2. Norm PN-EN ISO 12100-1 Safety of machinery –Basic concepts, principles for design – part 1: Basic terminology, Methodology.

3. Norm PN-EN 1708-1 Welding — Basic welded joint details in steel Part 1: Pressurized components

4. Norm PN-EN 287-1+A1 Welder Approval Testing. Steel

The product has the marks 20-08-2012.



Person approving the documentation: Location: Sokółka, Date 28.05.2014

Patryk Kucharewicz
(Name, Surname, Signature)

WARRANTY CARD FOR THE STEEL BOILERS, CENTRAL HEATING WATER BOILER

Power kW Type: Number:

Production date:

Purchase date:

Buyer's name:

Address:

.....
Date of purchase and seal

.....
I agree to the warranty conditions
Buyer's signature

WARRANTY CLAIM

Client's details:

.....

(first name, second name, address, contact number)

Purchase document number date:

Payment document number:

Seller's signature:

Warranty commencement conditions

1. Payment confirmation from the point of sale is the condition of warranty procedure commencement.
2. The warranty card is the only condition for free repair.
3. The Purchaser is obligated to cover the costs of BATALION Patryk Kucharewicz company in case of unnecessary calling and work of support unit.
4. Legible signature of the Purchaser to confirm the familiarisation with the warranty procedure conditions.

.....
(legible signature of Purchaser)

.....
(Warrant's signature)

I declare, that I have read and understood the Warranty Conditions under which I am claiming warranty and I allow my personal data to be processed for the purpose of warranty, in accordance with the Personal Data Protection Act dated 29/08/1997 (Dz. Ust. No. 133, item 883).

.....
(legible signature of Purchaser)

The Producer is obligated to take warranty actions within 30 days from receiving the claim in writing on the producer's form.

Batch and product number:

Name of the product under warranty:

Warranty period: valid invalid

Detailed description of the fault:

.....

.....

.....





WARRANTY CARD

BATALION

Purchaser's Copy

Sokółka, date20.....

WARRANTY CLAIM NO.R/20.....

Client's details:

Purchase document no.:

First name and last name:

Full name of the purchased product:

Address:

Phone no.:

Warranty expiry date: valid invalid

Detailed description of the fault:

The Purchaser is obligated to cover the costs of METAL FACH Jacek Kucharewicz company if the warranty claim has been rejected.

.....
(legible signature of Purchaser)

.....
(Warrant's signature)

BATALION

The original for the Warrant
(attach to the claim)

Sokółka, date20.....

WARRANTY CLAIM NO.R/20.....

Client's details:

Purchase document no.:

First name and last name:

Full name of the purchased product:

Address:

Phone no.:

Warranty expiry date: valid invalid

Detailed description of the fault:

The Purchaser is obligated to cover the costs of METAL FACH Jacek Kucharewicz company if the warranty claim has been rejected.

.....
(legible signature of Purchaser)

.....
(Warrant's signature)

BATALION 27

BATALION

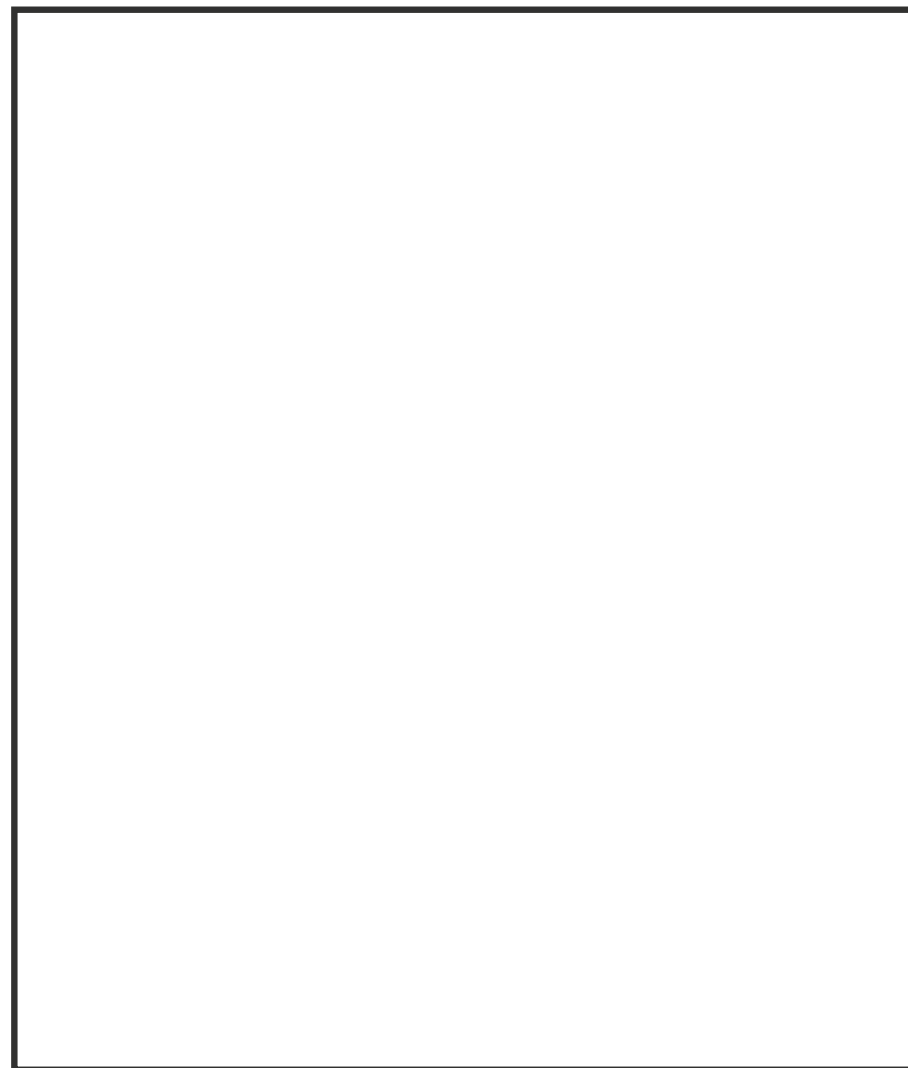

**BATALION PATRYK KUCHAREWICZ
16-100 SOKÓŁKA, UL. SIKORSKIEGO 66**